

# MiniMax 100 & 100 SC ABOVEGROUND POOL & SPA HEATER OPERATION & INSTALLATION MANUAL

IMPORTANT SAFETY INSTRUCTIONS  
READ AND FOLLOW ALL INSTRUCTIONS  
SAVE THESE INSTRUCTIONS

## ⚠ WARNING

### FOR YOUR SAFETY - READ BEFORE OPERATING

**Warning:** If you do not follow these instructions exactly, a fire or explosion may result, causing property damage, personal injury or loss of life. Call (800) 831-7133 for additional free copies of these instructions.

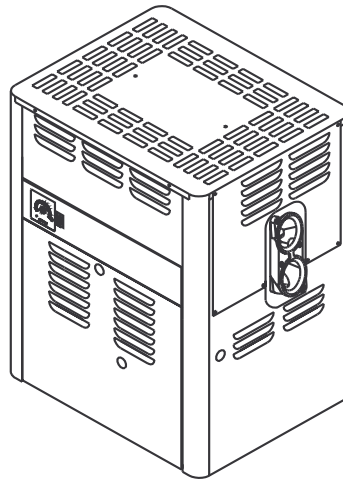

U.S. Patent Numbers  
5,201,307 - 4,595,825

To  
Consumer  
Retain For  
Future  
Reference

## ⚠ WARNING

**Warning:** Improper installation, adjustment, alteration, service or maintenance can cause property damage, personal injury or death. Installation and service must be performed by a qualified installer, service agency or the gas supplier.

### For Your Safety

#### WHAT TO DO IF YOU SMELL GAS

- Do not try to light any appliance.
- Do not touch any electrical switch; do not use any phone in your building.
- Immediately call your gas supplier from a neighbor's phone. Follow the gas supplier's instructions.
- If you cannot reach your gas supplier, call the fire department.

Do not store or use gasoline or other flammable vapors and liquids in the vicinity of this or other appliances.

Pentair Pool Products  
1620 Hawkins Ave., Sanford, NC 27330 • (919) 774-4151  
10951 West Los Angeles Ave., Moorpark, CA 93021 • (805) 523-2400

# TABLE OF CONTENTS

<b>Introduction</b> .....	<b>3</b>
Codes .....	3
<b>Warranty Information</b> .....	<b>4</b>
<b>Operation</b> .....	<b>4</b>
Safety Rules .....	4
<b>Direct Spark Ignition Lighting/Operation - Natural &amp; Propane</b> .....	<b>5</b>
Safety Instructions .....	5
Operating Instructions .....	5
To Turn Off Gas to Heater .....	5
<b>Millivolt Lighting/Operation - Natural &amp; Propane</b> .....	<b>6</b>
Safety Instructions .....	6
Lighting Instructions .....	6
To Turn Off Gas to Heater .....	6
Operating (Controls) .....	7
Heater Operation .....	7
General .....	7
Controls Operation .....	7
<b>Maintenance</b> .....	<b>10</b>
Maintenance Instructions .....	10
Energy Saving Tips .....	10
Spring and Fall Operation .....	10
Winter Operation .....	10
<b>Chemical Balance</b> .....	<b>11</b>
Pool and Spa Water .....	11
<b>Installation Instructions</b> .....	<b>12</b>
Specifications .....	12
Outdoor Installation .....	12
Indoor Installation .....	12
<b>Plumbing Connections</b> .....	<b>13</b>
Manual Bypass .....	13
Valves .....	13
Pressure Switch .....	13
<b>Water Connections</b> .....	<b>14</b>
Quick-Flange II Installation Instructions .....	14
<b>Gas Connections</b> .....	<b>15</b>
Gas Line/Installation .....	15
Pipe Sizing Chart/Gas Pressure Requirements .....	15
Regulated Manifold Pressure Test .....	15
Gas Pressure Settings .....	15
<b>Ventilation</b> .....	<b>16</b>
Outdoor Installation .....	16
Indoor Installation .....	17
Vent Test .....	18
Stack Type Indoor Draft Hood Kit .....	18
Indoor Draft Hood Kit .....	18
<b>Electrical</b> .....	<b>18</b>
Transformer Wiring Instruction .....	18
Electronic Direct Spark Ignition Wiring Diagram .....	19
Millivolt Wiring Diagram .....	19
<b>Trouble Shooting (General)</b> .....	<b>20</b>
<b>Parts List &amp; Exploded View</b> .....	<b>21, 22</b>
<b>Warranty Information</b> .....	<b>23</b>

# Introduction

## MiniMax 100 & 100 SC ABOVEGROUND POOL AND SPA HEATERS

Congratulations on your purchase of a MiniMax 100 high performance heating system. Proper installation and service of your new heating system and correct chemical maintenance of the water will ensure years of enjoyment. The MiniMax 100 is a compact, lightweight and efficient gas fired high performance aboveground pool and spa heater that can be connected to schedule 40 CPVC or ABS pipe and has a built-in top. Unless noted otherwise, all instructions refer to both the MiniMax 100 and MiniMax 100 SC heaters designated collectively as the "MiniMax 100". The heater features include the following features.

- Reliable direct-spark ignition (DSI) system available in propane or natural gas versions.
- Millivolt standing pilot versions in propane and natural gas, when no convenient line power is present.
- Fuel gas input of 100,000 btu/hr with thermal efficiency in excess of 82%, (74,999 for the SC Model).
- Quiet and dependable operation from packaged burner system proven reliable in worldwide usage.
- Heat exchanger constructed of premium non-corroding materials including bronze headers standard.
- The controls have been designed to be very easy to troubleshoot and very easy to access and replace in the rare event of a malfunction-making the MiniMax 100 user friendly.

### IMPORTANCE NOTICES FOR THE INSTALLER AND OPERATOR.

The manufacturer's warranty may be void if, for any reason, the heater is improperly installed and /or operated. Be sure to follow the instructions set forth in this manual.

These heaters are designed for the heating of swimming pools and spas, and should never be employed for use as space heating boilers, general purpose water heaters, or for the heating of salt water.

### CODES

The installation must conform with local codes or in the absence of local codes with the latest National Fuel Gas Code, ANSI Z223.1, and the latest edition of the National Electrical Code, NFPA 70.

Installation in Canada to be made in accordance with the latest CAN/CGA-B149.1 or .2 and CSA C22.1 Canadian Electric Code, part 1.



This instruction manual provides operating instructions, installation, and service information for the MiniMax 100 high performance heater. The information in this manual applies to the MiniMax 100, and 100 SC, natural gas and propane, DSI; and MiniMax 100 millivolt standing pilot heater models.

It is very important the owner/installer read and understand the section covering installation and recognize the local code and state codes before installing the MiniMax 100. **History and experience have shown that most heater damage is caused by improper installation practices.**

## WARRANTY INFORMATION

The MiniMax 100 pool heater is sold with a limited factory warranty. *Specific details are described on the back cover of this manual and a copy of the warranty and warranty registration card are included with the product.* Return the warranty registration card after filling in the serial number from the rating plate inside the heater. For ordering parts, you should indicate model and serial numbers of the heater. If the parts are requested for warranty, you must also indicate the date of installation.

**Pentair Pool Products high standards of excellence include a policy of continuous product improvement resulting in your state-of-the-art heater. We reserve the right to make improvements which change the specifications of the heater without incurring an obligation to update current heater equipment.**

## Operation



### SAFETY RULES

1. Spa or hot tub water temperatures should never exceed 104 °F (40 °C). A temperature of 100 °F (38 °C) is considered safe for a healthy adult. Special caution is suggested for young children.
2. Drinking of alcoholic beverages before or during spa or hot tub use can cause drowsiness which could lead to unconsciousness and subsequently result in drowning.
3. Pregnant women beware! Soaking in water above 102° F. (39° C.) can cause fetal damage during the first three months of pregnancy (resulting in the birth of a brain-damaged or deformed child). Pregnant women should stick to the 100° F. (38° C.) maximum rule.
4. Before entering the spa or hot tub, the user should check the water temperature with an accurate thermometer. Spa or hot tub thermostats may err in regulating water temperatures by as much as 4° F. (2.2° C.).
5. Persons with medical history of heart disease, circulatory problems, diabetes or blood pressure problems should obtain their physician's advice before using spas or hot tubs.
6. Persons taking medication which induce drowsiness, such as tranquilizers, antihistamines or anticoagulants should not use spas or hot tubs.

### WARNING

Should overheating occur or the gas supply fail to shut off, turn off the manual gas control valve to the appliance. Do not use this heater if any part has been under water. Immediately call a qualified service technician to inspect the heater and to replace any part of control system and gas control which has been under water.

# MINIMAX 100 DIRECT-SPARK IGNITION LIGHTING/OPERATION-NATURAL GAS & PROPANE

## FOR YOUR SAFETY: READ BEFORE LIGHTING

### ⚠ WARNING



If you do not follow these instructions exactly, a fire or explosion may result causing personal injury, loss of life and property damage.

Since propane gas is heavier than air, escaping propane will accumulate and remain at ground level. Do not attempt to light the heater. If you suspect a propane leak, lighting the heater can result in a fire or explosion which can cause personal injury, death, and property damage.

- A. This heater is equipped with an ignition device which automatically lights the main burner. Do not try to light the main burner by hand.
- B. **BEFORE OPERATING** smell all around the heater area for gas. Be sure to smell next to the floor because some gas is heavier than air and will settle on the floor.
- Do not try to light any heater.
- Do not touch any electric switch; do not use any phone in your building.
- Immediately call your gas supplier from a neighbor's phone. Follow the gas supplier's instructions.
- If you cannot reach your gas supplier, call the Fire Department.
- C. Use only your hand to push in or turn the gas control knob. Never use tools. If the knob will not push in or turn by hand, don't try to repair it. Call a qualified service technician. Forced or attempted repair may result in a fire or explosion.
- D. Do not use this heater if any part has been under water. Immediately call a qualified service technician to inspect the heater and to replace any part of the control system and any gas control which has been under water.

### WHAT TO DO IF YOU SMELL GAS

## OPERATING INSTRUCTIONS

1. **STOP!** Read the safety information above.
2. Set the thermostat to lowest setting, fully counterclockwise. 
3. Turn off electric power to the heater.
4. This heater is equipped with an ignition device which automatically lights the main burner. Do not try to light the main burner by hand.
5. Remove the control access door.
6. Turn the gas control lever horizontally to "OFF"; see Figure 1.
7. Wait five (5) minutes to clear out any gas. If you then smell gas, **STOP!** Follow "B" in the safety information above. If you don't smell gas, go to the next step.
8. Turn the gas control lever vertically to "ON".
9. Replace the control access door.
10. Turn on the electrical power to the heater.
11. Set the thermostat to the desired setting.
12. If the heater will not operate, follow the instructions "To Turn Off Gas To Heater" and call your service technician or gas supplier.

Figure 1.



### TO TURN OFF GAS TO HEATER

1. Set the thermostat to lowest setting.
2. Turn off all electric power to the heater if service is to be performed.
3. Remove control access door.
4. Turn gas control lever horizontally to "OFF".  
**Do not force.**
5. Replace control access door.

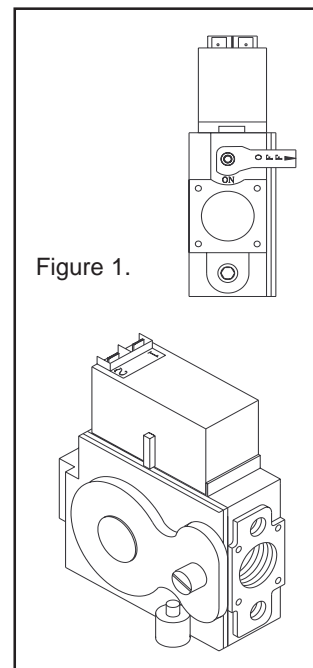
# MILLIVOLT LIGHTING/OPERATION- NATURAL GAS & PROPANE

## FOR YOUR SAFETY: READ BEFORE LIGHTING

### ⚠ WARNING





If you do not follow these instructions exactly, a fire or explosion may result causing personal injury, loss of life and property damage.

Since propane gas is heavier than air, escaping propane will accumulate and remain at ground level. Do not attempt to light the heater. If you suspect a propane leak, lighting the heater can result in a fire or explosion which can cause personal injury, death, and property damage.

- A. This heater has a pilot that must be lit manually. When lighting the pilot follow these instructions exactly.
- B. **BEFORE LIGHTING** smell all around the heater area for gas. Be sure to smell next to the floor because some gas is heavier than air and will settle on the floor.
- Do not try to light any heater.
- Do not touch any electric switch; do not use any phone in your building.
- Immediately call your gas supplier from a neighbor's phone. Follow the gas supplier's instructions.
- If you cannot reach your gas supplier, call the Fire Department.
- C. Use only your hand to push in or turn the gas control knob. Never use tools. If the knob will not push in or turn by hand, don't try to repair it. Call a qualified service technician. Forced or attempted repair may result in a fire or explosion.
- D. Do not use this heater if any part has been under water. Immediately call a qualified service technician to inspect the heater and to replace any part of the control system and any gas control which has been under water.

## LIGHTING INSTRUCTIONS

1. **STOP!** Read the safety information above.
2. Set the thermostat to the lowest setting.
3. Turn off all electric power to the heater.
4. Remove the control access door.
5. Push in the gas control valve slightly and turn clockwise  to "OFF"; see Figure 2.
6. **The knob cannot be turned from "PILOT" to "OFF" unless the knob is pushed in slightly. Do not force.**
7. Wait five (5) minutes to clear out any gas. If you then smell gas, **STOP!** Follow "B" in the safety information above. If you don't smell gas, go to next step.
8. Turn the knob on the gas control to counterclockwise  to "PILOT"; see Figure 3.
9. Push the control knob all the way and hold in. Immediately light the pilot with Presslite matchless ignition system by pressing the red igniter button, (located at panel next to the gas valve). Continue to hold the control knob in for about (1) minute after the pilot is lit. Release knob and it will pop back up. Pilot should remain lit. If it goes out, repeat steps 4 through 7.
10. If the knob does not pop up when released, stop and immediately call your service technician or gas supplier.
11. If the pilot, see Figure 4, will not stay lit after several tries, turn the gas control knob to "OFF" and call your service technician or gas supplier.
12. Turn the gas control knob counterclockwise to "ON". 
13. Replace the control access door.
14. If the heater will not operate, follow the instructions "To Turn Off Gas To Heater" and call your service technician or gas supplier.

## TO TURN OFF GAS TO HEATER

1. Set the thermostat to lowest setting.
2. Turn off all electric power to the heater if service is to be performed.
3. Remove control access door.
4. Turn gas control lever horizontally to "OFF". **Do not force.**
5. Replace control access door.

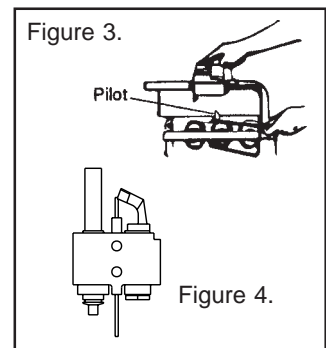
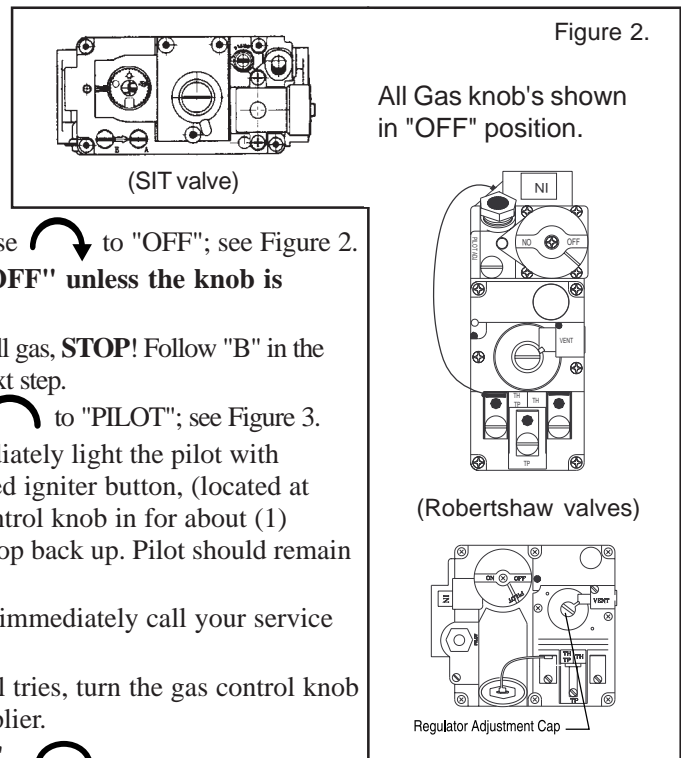

## OPERATING (CONTROLS)

### DIRECT SPARK ELECTRONIC AND MILLIVOLT MODELS

For convenience and economy all MiniMax 100 heaters are equipped with a thermostat on the front of the heater control panel; see Figure 5.

Direct Spark MiniMax 100 heaters are equipped with an electronic thermostat while Millivolt MiniMax 100 heaters have a mechanical thermostat.

The Pool/Off/Spa switch allows the heater to be turned off when heating is not desired.

1. "ON" position - Maintains selected pool temperature.
2. "OFF" position - Heater will not come on regardless of drop in pool temperature.

### THERMOSTAT ADJUSTMENT

The knob with locking feature eliminates the need for constant thermostat adjustments. Set the knob pointer to the desired spa temperature.

#### NOTE

To eliminate error due to piping heat losses measure pool temperature with an accurate thermometer directly at the pool or spa.

If further adjustment is needed rotate the knob until the desired temperature is obtained. This knob position corresponding to your desired maximum pool or spa temperature may now be preset (locked) by the knob stopper which prevents the knob from being turned beyond the maximum temperature you set.

### THERMOSTAT KNOB STOPPER

Each thermostat is equipped with a mechanical stop that can be locked or unlocked with use of a screwdriver to prevent temperatures in excess of that desired by the user; see Figure 5.

The maximum setting can be adjusted by loosening the screw "A" and turning the stopper dial to desired maximum setting. Lock the setting by tightening the screw. The Mechanical stop is under the knob. Ensure that the knob is stopping at the correct position when the knob is rotated clockwise from a lower temperature position.

## HEATER OPERATION

### GENERAL

The MiniMax 100 DSI employs a microprocessor based Direct Spark Ignition (DSI) system to light the main burner and therefore has no pilot. The ignition circuit operates at 24 VAC and requires that line voltage 115/230 be supplied to the heater.

The MiniMax 100 MV (Millivolt) requires no external power source and the control circuit derives all its power from the energy generated from the standing pilot/ thermopile-generator combination. *Note: Some states, including California, have energy conservation regulations preventing the sale and use of certain standing pilot (millivolt) equipment.*

The MiniMax 100 DSI Control utilizes a microprocessor to continually and safely monitor, analyze, and control the proper operation of the gas burner. The DSI Control features LED diagnostics, automatic one hour reset, and flame current test pins. The LED is located on the DSI.

### CONTROLS OPERATION (DSI SYSTEM)

#### Heat Mode

1. When a call for heat is received from the thermostat supplying 24 volts to TH terminal on control, the control will reset, perform a self check routine, and flash the diagnostic LED for up to four seconds. After a brief delay the gas valve is energized and the ignition electrode begins to spark for the four (4) second trial for ignition (TFI) period.
2. When flame is detected during the trial for ignition, sparking is shut-off immediately and the gas valve remains energized. The thermostat and main burner flame are constantly monitored to assure the system continues to operate properly.
  - a. When the thermostat is satisfied and the demand for heat ends, the main valve is de-energized immediately.

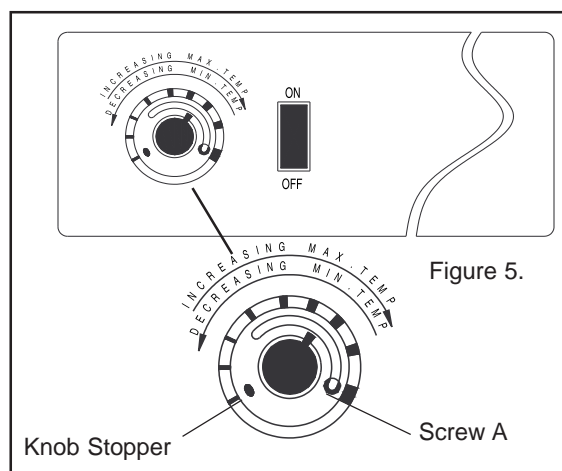

Figure 5.

Failure to Light- Lockout

1. Should the main burner fail to light, or flame is not detected during the trial-for-ignition (TFI) period the control will go into lockout and the valve will be turned off immediately.
2. Recovery from lockout requires a manual reset by resetting the thermostat or turning off the ON/OFF switch for a minimum period of 5 seconds.

**IMPORTANT!**

IT IS RECOMMENDED THAT NO MORE THAN TWO IGNITION ATTEMPTS IN SUCCESSION BE PERFORMED FOR NATURAL GAS SYSTEMS . BEFORE FURTHER IGNITION ATTEMPTS WAIT AT LEAST FIVE MINUTES FOR GAS TO CLEAR.

FOR PROPANE (LPG) SYSTEMS ALLOW AT LEAST FIVE (5) MINUTES BETWEEN IGNITION ATTEMPTS FOR THIS HEAVIER-THAN-AIR GAS TO SAFELY DISSIPATE. AFTER TWO UNSUCCESSFUL IGNITION ATTEMPTS WITH PROPANE OPEN THE BURNER ACCESS DOOR AND WAIT AT LEAST THIRTY (30) MINUTES BEFORE REPLACING DOOR TO ATTEMPT FURTHER IGNITION ATTEMPTS.

**NOTE**

Normally the heater will light in the first or second attempt. And with the exception of a new installation or one that has been shut down for an extended period, where there is considerable air trapped in the gas supply line, unsuccessful ignition indicates other problems with the ignition system - such as an unclean ignition electrode impeding flame sensing.

3. If the thermostat is still calling for heat one hour after a lockout the control will automatically reset and attempt to ignite the burner again.

Flame Failure-Re-Ignition

1. If the established flame signal is lost while the burner is operating, the control will respond within 0.8 seconds. The H.V. spark will be energized for a trial for ignition period in an attempt to relight the burner.
  - a. If the burner does not light the control will de-energize the gas valve, shutting off the gas flow, and the control will go into lockout as described above in “Failure to Light-Lockout”. If flame is re-established, normal operation resumes.

Control Fault -Diagnostic LED Conditions

Error Mode	LED Indication
Internal Control Failure	Steady on
Flame Sense Fault	2 flashes
Ignition Lockout	3 flashes

The DSI Ignition Control can be accessed after removing the heater’s front control panel. The diagnostic LED located on the top of the DSI control will flash on for 1/4 second, then off for 1/4 second during a fault condition. The pause between fault codes is 3 seconds.

### Proper Electrode Location

Proper location of the ignition electrode assembly is important for optimum and safe system performance. The electrode assembly should be located as noted in Figure 6. The electrode assembly is NOT field repairable and must be replaced if damaged.

### Service Checks

Symptom	Cause/Cure
1. Dead	A. Miswired B. Transformer bad C. Fuse/circuit breaker open D. Bad control (check LED for steady on)
2. Thermostat on, no spark	A. Miswired B. Bad thermostat no voltage @ terminal TH
3. Valve on, no spark	A. Shorted Ign. electrode B. Open HV Ign cable C. Miswired D. Bad DSI control
4. Spark on, no valve	A. Valve coil open B. Open valve wire C. Bad control (also check voltage between V1 & V2)
5. Flame okay during TFI, no flame sense (after TFI)	A. Bad electrode B. Bad S1 or HV wire C. Poor ground at burner D. Poor flame (check flame sensor current, which follows)

### Flame Sensor Current Check

Flame current is the current which passes through the flame sensor to ground. The minimum flame current necessary to keep system from lockout is 0.7 microamperes. To measure flame current, connect DC microammeter to the FC- FC+ terminals as shown in Figure 7. The meter should read 0.7 microamperes or higher when the heater is firing.

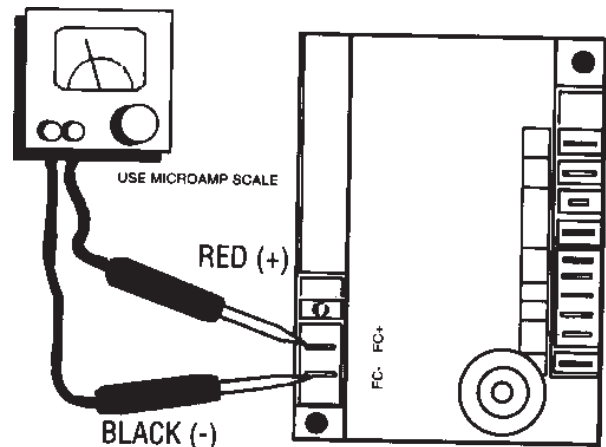

Figure 7.

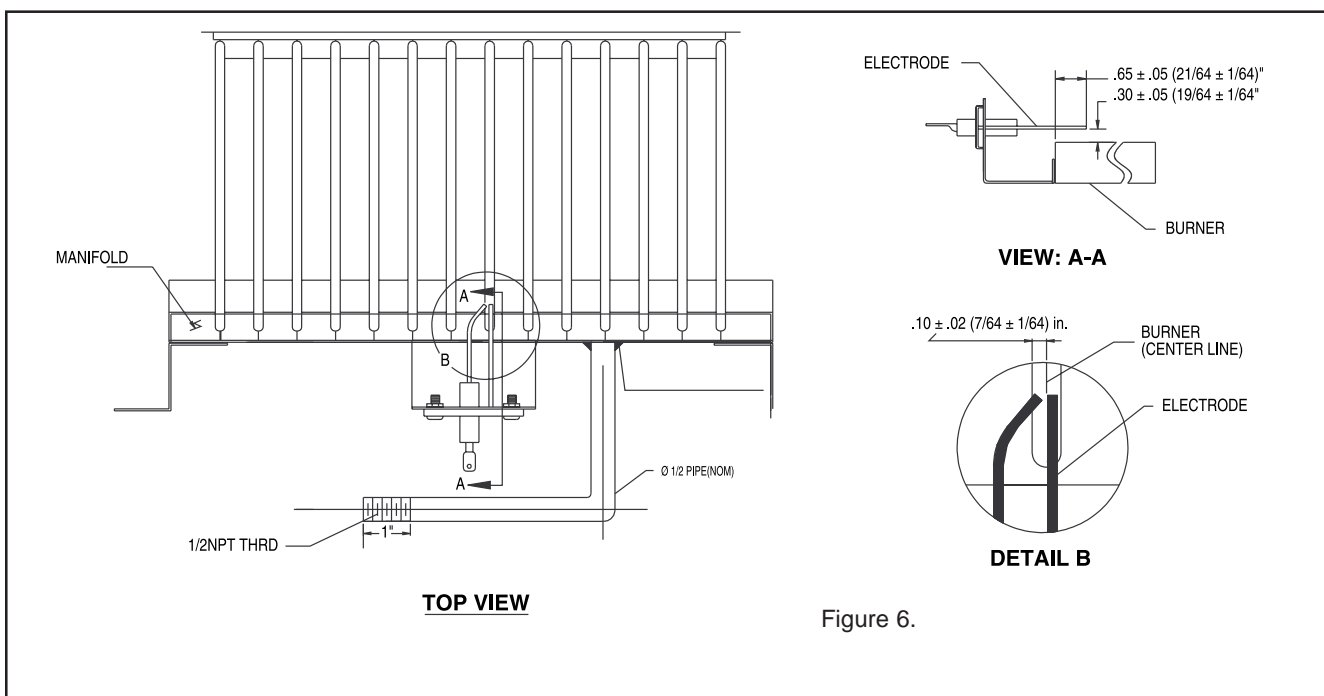

Figure 6.

# Maintenance

## MAINTENANCE INSTRUCTIONS

It is recommended that you check the following items at least every six months and at the beginning of every swimming season.

1. Examine the venting system. Make sure there are no obstructions in the flow of combustion and ventilation air.
2. Visually inspect the main burner and the pilot burner flame (on millivolt models). The normal color of the flame is blue. When flame appears yellow, burners should be inspected and cleaned; see Figure 8.
3. Keep the burner area clear and free from combustibles and flammable liquids.

## ENERGY SAVING TIPS

1. If possible, keep pool or spa covered when not in use. This will not only cut heating costs, but also keep dirt and debris from settling in the pool and conserve chemicals.
2. Reduce the pool thermostat setting to 78° F. or lower. This is accepted as being the most healthy temperature for swimming by the American Red Cross.
3. Use an accurate thermometer.
4. When the proper maximum thermostat settings have been determined, tighten the thermostat knob stopper.
5. Set time clock to start circulation system no earlier than daybreak. The swimming pool loses less heat at this time.
6. For pools that are only used on the weekends, it is not necessary to leave the thermostat set at 78 °F. Lower the temperature to a range that can be achieved easily in one day. Generally, this would be 10° F. to 15° F., if pool heater is sized properly.
7. During the winter or while on vacation, turn heater off.
8. Set up a regular program of preventative maintenance for the heater each new swimming season. Check heat exchanger, controls, burners, operation, etc.

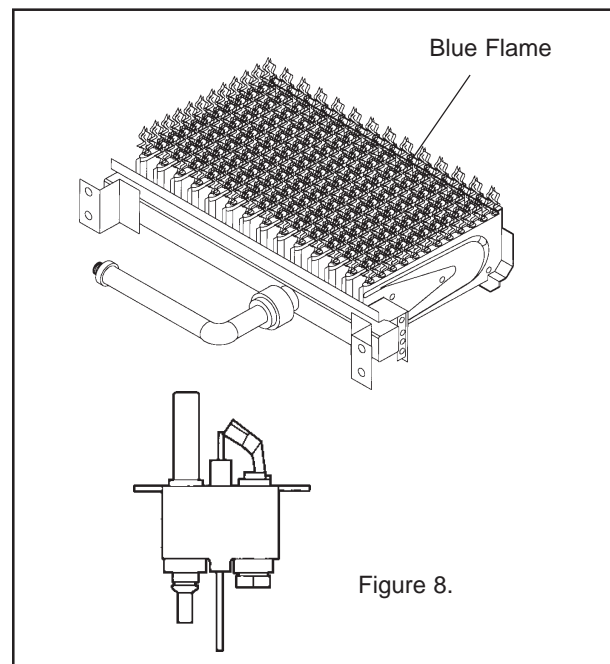

## SPRING AND FALL OPERATION

If the pool is being used occasionally, do not turn the heater completely off. Set the thermostat down to 65° F. This will keep the pool and the surrounding ground warm enough to bring the pool up to a comfortable swimming temperature in a shorter period of time.

## WINTER OPERATION

If the pool won't be used for a month or more, turn the heater off at the main gas valve. For areas where there is no danger of water freezing, water should circulate through the heater all year long, even though you are not heating your swimming pool. This heater should not be operated outdoors at temperatures below 32° F. (0° C.). Where freezing is possible, it is necessary to drain the water from the heater. This may be done by opening the drain valve located at the inlet/outlet header allowing all water to drain out of the heater. It would be a good practice to use compressed air to blow the water out of the heat exchanger.

# CHEMICAL BALANCE

## POOL AND SPA WATER

Your Pentair Pool Products pool heater was designed specifically for your spa or pool and will give you many years of trouble free service provided you keep your water chemistry in proper condition.

Three major items that can cause problems with your pool heater are improper pH, disinfectant residual, and total alkalinity. These items, if not kept properly balanced, can shorten the life of the heater and cause permanent damage.

### WARNING

Heat exchanger damage resulting from chemical imbalance is not covered by the warranty.

### WHAT A DISINFECTANT DOES

Two pool guests you do not want are algae and bacteria. To get rid of them and make pool water sanitary for swimming - as well as to improve the water's taste, odor and clarity - some sort of disinfectant must be used.

Chlorine and bromine are universally approved by health authorities and are accepted disinfecting agents for bacteria control.

### WHAT IS A DISINFECTANT RESIDUAL?

When you add chlorine or bromine to the pool water, a portion of the disinfectant will be consumed in the process of destroying bacteria, algae and other oxidizable materials. The disinfectant remaining is called chlorine residual or bromine residual. You can determine the disinfectant residual of your pool water with a reliable test kit, available from your local pool supply store.

You must maintain a disinfectant residual level adequate enough to assure a continuous kill of bacteria or virus introduced into pool water by swimmers, through the air, from dust, rain or other sources.

It is wise to test pool water regularly. Never allow chlorine residual to drop below 0.6 ppm (parts per million). The minimum level for effective chlorine or bromine residual is 1.4 ppm.

**pH** - The term pH refers to the acid/alkaline balance of water expressed on a numerical scale from 0 to 14. A test kit for measuring pH balance of your pool water is available from your local pool supply store; see Table 1. Muriatic Acid has a pH of about 0. Pure water is 7 (neutral). Weak Lye solution have a pH of 13-14.

**RULE:** 7.4 to 7.6 is a desirable pH range. It is essential to maintain correct pH, see Table 2.

If pH becomes too high (over alkaline), it has these effects:

1. Greatly lowers the ability of chlorine to destroy bacteria and algae.
2. Water becomes cloudy.
3. There is more danger of scale formation on the plaster or in the heat exchanger.
4. Filter elements may become blocked.

If pH is too low (over acid) the following conditions may occur:

1. Excessive eye burn or skin irritation.
2. Etching of the plaster.
3. Corrosion of metal fixtures in the filtration and recirculation system, which may create brown, blue, green, or sometimes almost black stains on the plaster.
4. Corrosion of copper in the heater, which may cause leaks.
5. If you have a sand and gravel filter, the alum used as a filter aid may dissolve and pass through the filter.

**CAUTION:** *Do not test for pH when the chlorine residual is 3.0 ppm or higher, or bromine residual is 6.0 ppm or higher. See your local pool supply store for help in properly balancing your water chemistry.*

**RULE:** Chemicals that are acid lower pH. Chemicals that are alkaline raise pH.

### ALKALINITY High - Low:

"Total alkalinity" is a measurement of the total amount of alkaline chemicals in the water, and control pH to a great degree. (It is not the same as pH which refers merely to the relative alkalinity/acidity balance.) Your pool water's total alkalinity should be 100 - 140 ppm to permit easier pH control.

A total alkalinity test is simple to perform with a reliable test kit. You will need to test about once a week and make proper adjustments until alkalinity is in the proper range. Then, test only once every month or so to be sure it is being maintained. See your local pool dealer for help in properly balancing the water chemistry.

Table 1. **pH Chart**

Strongly Acid					Neutral					Strongly Alkaline				
0	1	2	3	4	5	6	7	8	9	10	11	12	13	14

Table 2. **pH Control Chart**

6.8	7.0	7.2	7.4	7.6	7.8	8.0	8.2	8.4
Add Soda Ash or Sodium Bicarbonate		Marginal	Ideal		Marginal	Add Acid		

# Installation Instructions

## SPECIFICATIONS

**IMPORTANT NOTICE:** These installation instructions are designed for use by qualified personnel only, trained especially for installation of this type of heating equipment and related components. Some states require installation and repair by licensed personnel. If this applies in your state, be sure your contractor bears the appropriate license.

The heater must be installed on a level surface consisting entirely of, or a combination of, noncombustible materials such as steel, iron, brick, tile, concrete, slate, or plaster. Do not install on carpeting. The heater must be installed to keep specific clearances on all sides for service and inspection.

### OUTDOOR INSTALLATION

Stackless, applies to all  
MiniMax 100 outdoor models

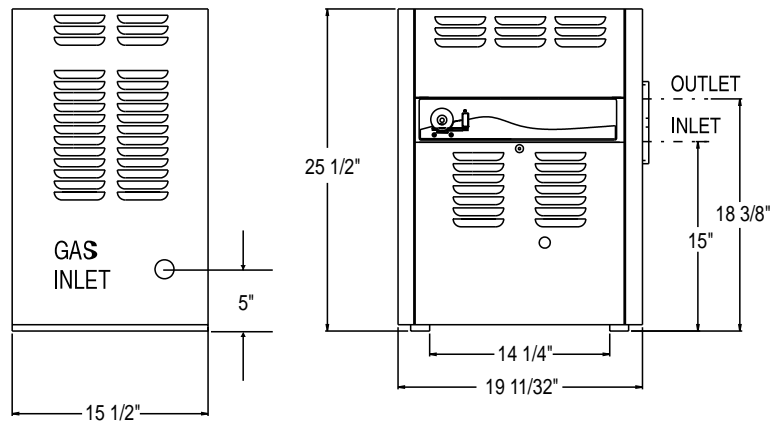

Outdoor Installation

### INDOOR INSTALLATION

Applies to all MiniMax 100  
indoor models,  
Draft hood stack diameter = 5 in.

Stack (USA only)  
Outdoor shelter (Canadian)

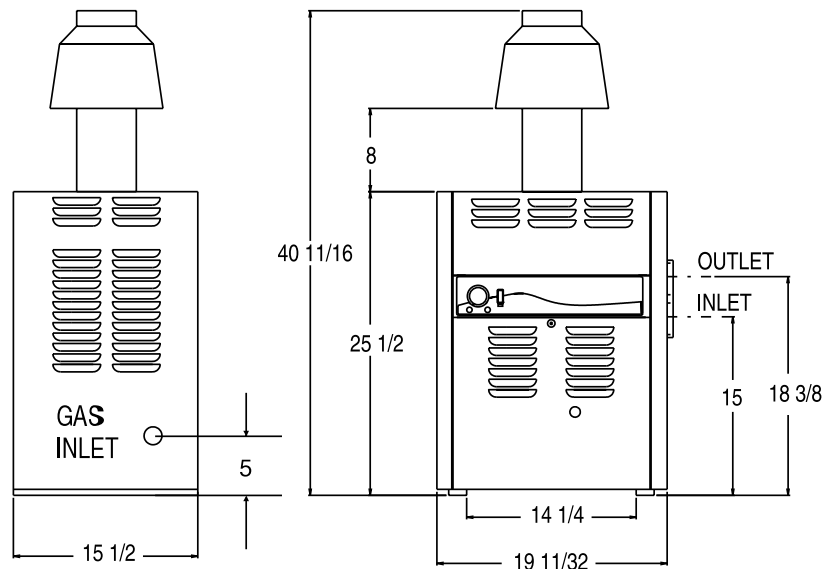

Indoor Installation

## PLUMBING CONNECTIONS

The MiniMax 100 heater has the unique capability of direct schedule 40 or 80 CPVC/ABS/PVC plumbing connections. Either a Quick-Flange or Quick-Flange II (depending on model ordered) has been included with the MiniMax 100 to insure conformity with Pentair Pool Products recommended CPVC/ABS plumbing procedure; see Figure 9. Other plumbing connections can be used. The instructions on the following pages show the methods for successfully connecting plumbing to the inlet/outlet header with either the Quick-Flange or Quick-Flange II.

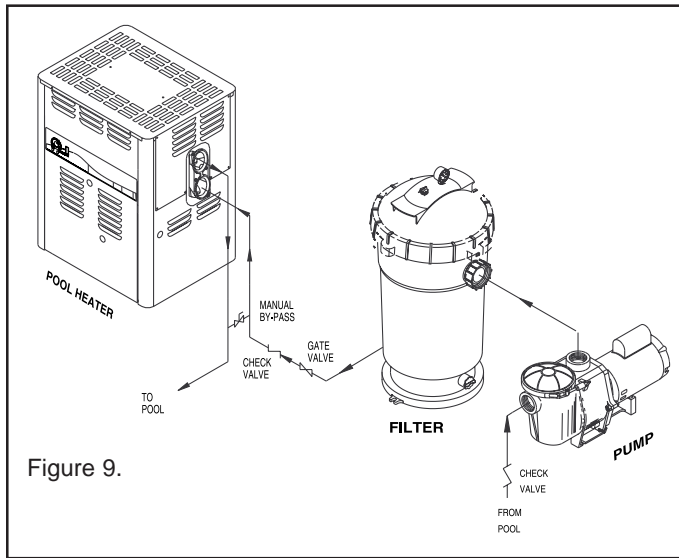

Figure 9.

## MANUAL BY-PASS

Where the flow rate exceeds the maximum 80 GPM, a manual by-pass should be installed and adjusted. After adjustments are made, the valve handle should be removed to avoid tampering.

Model	Min.	Max.*
100	20	80

\* Do not exceed the maximum recommended flow rate for the connecting piping.

## VALVES

When any equipment is located below the surface of the pool or spa, valves should be placed in the circulation piping system to isolate the equipment from the pool or spa.

Check valves are recommended to prevent back siphon; see Figure 10.

*Caution: Exercise care when installing chemical feeders so as to not allow back siphoning of chemical into the heater, filters or pump.*

## PRESSURE SWITCH

The pressure switch will keep the circuit open when the pump is not on and operating. When the filter pump turns on, the pressure switch closes the circuit and the heater will operate. When the heater is installed below water level of a spa or pool, adjustment of the pressure switch may be required. For adjustment of pressure switch, we recommend the following procedures.

1. Backwash the filter and clean the pump hair and lint basket before making any adjustment to the pressure switch.
2. Switch the circulation pump on and make sure it is primed.
3. Push the heater power switch on and set the thermostats to their highest temperature settings.
4. Clean the locktight off of the pressure switch adjustment knob threads.
5. Turn the adjustment knob clockwise or away from the micro-switch, until the heater shuts down; see Figure 11.
6. Turn the adjustment knob counter-clockwise 1/2 turn and the heater should re-fire.
7. Turn the pump off and the heater should shut down. If the heater does not shut down, repeat the procedure.
8. Switch the pump off and on several times to assure proper adjustment.

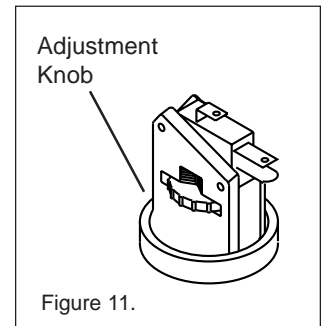

Figure 11.

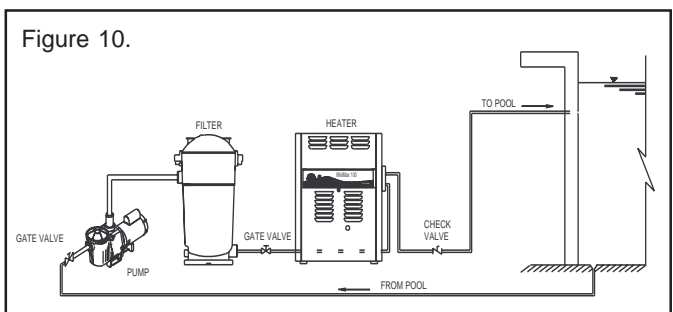

Figure 10.

## WATER CONNECTIONS

### QUICK-FLANGE II INSTALLATION INSTRUCTIONS

FOR 1½ SCHEDULE 40 CPVC or ABS PIPE or SCHEDULE 80 PVC  
(you may adapt to SCH 40 PVC 12 inches beyond the Quick Flange II)

(1½ in. npt x 1½ in. CPVC/ABS slip male adaptor may be required )

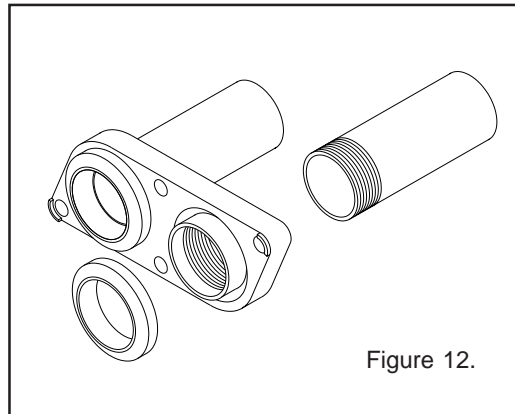

Figure 12.

1. Insert 2 in. rubber gaskets over 2 in. gasket retainer rings molded to bottom of Quick-Flange II; see Figure 12.
2. Bolt Quick-Flange II to header using supplied 3/8 in. bolts and 3/8 in. washers.
3. Using pipe dope, thread pipe directly to Quick-Flange II.
  - a. Or, first thread a 1½ in. npt x 1½ in. slip CPVC/ABS male adaptor (not supplied) to the Quick-Flange II, and after preparing the joint by sanding with a medium grit sandpaper, glue the pipe to the adaptor with a quality solvent glue.

---

#### NOTE

ALL VERSIONS OF THE MINIMAX 100 INCLUDE A QUICK-FLANGE II ADAPTOR

---

Each MiniMax 100 Quick-Flange II Accessory Kit, p/n 471083,

contains the following items:

One (1) Quick-Flange II unit

Two (2) 2 in. Rubber Gaskets

Four (4) 3/8 in. Bolts

Four (4) 3/8 in. Washers

---

## PRESSURE RELIEF VALVES

Where local, (or Canadian), codes require the use of a Pressure Relief Valve (PRV), the PRV may be installed in a tee fitting placed as close as possible to the heater water outlet with no intervening valves between the PRV and the heater.

## GAS CONNECTIONS

### GAS LINE INSTALLATIONS

Before installing the gas line, be sure to check which gas the heater has been designed to burn. This is important because different types of gas require different gas pipe sizes. The rating plate on the heater will indicate which gas the heater is designed to burn. Table 3 shows which size pipe is required for the distance from gas meter to the heater. The table is for natural gas at a specific gravity of .65 and propane at specific gravity of 1.5.

When sizing gas lines, calculate three (3) additional feet of straight pipe for every elbow used.

When installing the gas line, avoid getting dirt, grease or other foreign material in the pipe as this may cause damage to the gas valve, which may result in heater failure.

The gas meter should be checked to make sure that it will supply enough gas to the heater and any other heaters that may be used on the same meter.

The gas line from the meter will usually be of a larger size than the gas valve supplied with the heater. Therefore a reduction of the connecting gas pipe will be necessary. Make this reduction as close to the heater as possible.

The heater and any other gas appliances must be disconnected from the gas supply piping system during any pressure testing on that system, (greater than 1/2 PSIG).

The heater and its gas connection must be leak tested before placing the heater in operation. **Do not use flame to test the gas line.** Use soapy water or another nonflammable method.

**A manual main shutoff valve must be installed external to the heater.**

### ⚠️ WARNING

Do not install the gas line union inside the heater cabinet. This will void your warranty.

### ⚠️ CAUTION

The use of Flexible Connectors (FLEX) is NOT recommended as they cause high gas pressure drops.

Pipe Sized For Length Of Run In Equivalent Feet						
	1/2"		3/4"		1"	
Model	Nat	LP	Nat	LP	Nat	LP
100 DSI	20'	50'	50'	150'	150'	600'
100 MV	20'	50'	50'	150'	150'	600'
100 SC	20'	50'	50'	150'	150'	600'

Table 3.

### REGULATED MANIFOLD PRESSURE TEST

1. Attach the manometer to the heater jacket.
2. Shut off the main gas valve.
3. Remove 1/8" NPT plug on the outlet side of the valve and screw in the fitting from the manometer kit.
4. Connect the manometer hose to the fitting.
5. Fire the heater.
6. The manometer must read 4" WC for natural gas, 11" WC for propane gas, **while** the heater is operating.
7. For adjustment, remove the Regulator Adjustment Cap and using a screwdriver turn the screw clockwise to increase - counterclockwise to decrease gas pressure; see Figure 13.

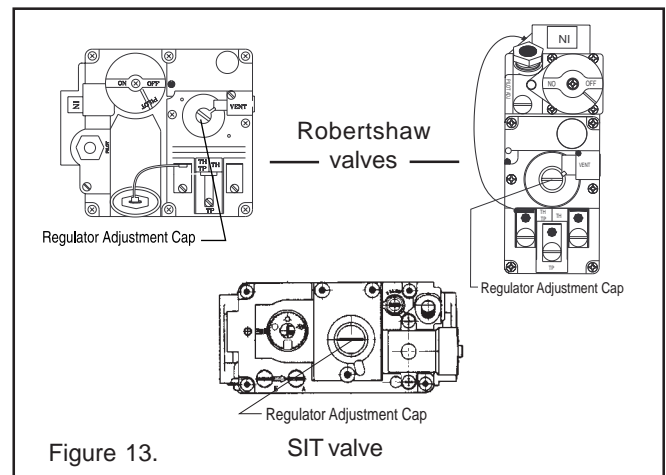

Figure 13.

### PENTAIR POOL PRODUCTS GAS PRESSURE SETTINGS\*

Normal Altitudes (0-2500 ft. Above Sea Level)	Natural	Propane
	Maximum inlet gas pressure	10" WC
Minimum inlet gas pressure	5" WC	12" WC
Normal manifold pressure	4" WC	11" WC
High Altitudes (2500-7000 ft. Above Sea Level)	Natural	Propane
	Maximum inlet gas pressure	10" WC
Minimum inlet gas pressure	5" WC	12" WC
Normal high altitude manifold pressure	3" WC	7" WC
* All Readings are taken with heater fired. Any adjustments made with heater off will give incorrect readings.		

Table 4.

## VENTILATION

### OUTDOOR INSTALLATION

This heater is certified by International Approval Services (AGA & CGA) for outdoor installation. If the heater is installed in very cold areas proper precautions are needed for freeze protection. The heater must be placed in a suitable area on a level, noncombustible surface. Do not install heater under an overhang with clearances less than 3 feet from top of the heater. The area under an overhang must be open on three side.

#### IMPORTANT!

In an outdoor installation it is important to protect your heater from water damage. Ensure water is diverted from overhanging eaves with a proper gutter/drainage system. The heater must be set on a level foundation for proper rain drainage.

The heater should not be installed closer than 6 inches to any fences, walls or shrubs at any side or back, nor closer than 18 inches at the plumbing side. A minimum clearance of 24 inches must be maintained at front of heater; see Figure 14.

#### IMPORTANT!

When locating the heater, consider that high winds can roll over or deflect off adjacent buildings and walls. Normally, placing the heater at least three feet from any wall will minimize downdraft.

***Unusually high prevailing wind condition and downdrafts may require the use of a stack type outdoor vent kit (available at additional cost).***

#### NOTE

This unit shall not be operated outdoors at temperatures below 0° F. for propane and -20° F. for natural gas.

#### NOTE

Overhangs must be such that flue products are not diverted into living spaces. From the point where the flue products leave the heater, that point MUST be a minimum of four (4) feet below, four (4) horizontally from or one (1) foot above any door, window or gravity inlet into the building; see Figure 15.

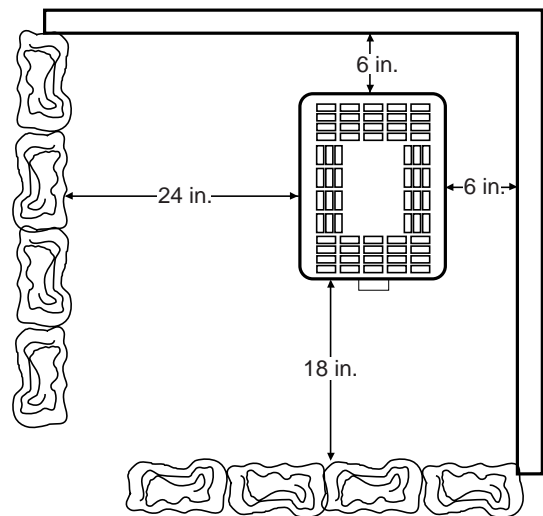

Figure 14.

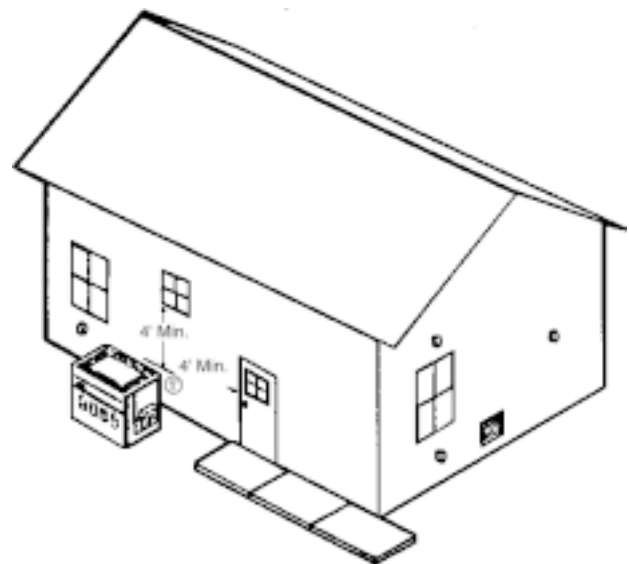

Figure 15.

## INDOOR INSTALLATION

The installation of venting system should conform with the latest edition of ANSI Z223.1, the National Fuel Gas Code, and/or in Canada, CAN/CGA-B149.1 or .2 or applicable provision of the local codes.

All products of combustion and vent gases must be completely removed to the outside atmosphere through a vent pipe which is connected to the draft hood. A vent pipe extension of the same size must be connected to the draft hood and extended at least 2 feet higher than highest point of the roof within a 10 foot horizontal radius, and at least 3 ft. higher than the point at which it passes through the roof, or as permitted by local code; see Figure 16. The vent should terminate with an approved vent cap (weather cap) for protection against rain or blockage by snow. Double-wall vent pipe and an approved roof jack shall be employed through the roof penetration. The use of double-walled type B vent pipe is recommended.

The draft hood must be installed so as to be in the same atmospheric pressure zone as the combustion air inlet to the pool heater. The certified (factory) draft hood **must not** be modified in any way and must be employed in every indoor installation.

The heater must be located as close as practical to a chimney or gas vent. The Heater should be installed at least 5 feet away from the pool or spa.

The heater must be placed in a suitable room on a non-combustible floor and in an area where leakage from heat exchanger or water connections will not result in damage to the area adjacent to the heater or the structure. When such locations cannot be avoided, it is recommended that a suitable drain pan with adequate drainage, be installed under the heater. The pan must not restrict air flow.

Installations in basements, garages, or underground structures where flammable liquids may be stored must have the heater elevated 18 inches from the floor using a noncombustible base. The following minimum clearances from combustible materials must be provided.

	Side	Front	Top
Water Connection	18 in.	24 in.	
Remaining	6 in.	6 in.	
Ceiling Clearance			36 in.*

\*To ceiling or roof.

### NOTE

The heater requires two uninterrupted air supply openings; one for ventilation and one to supply oxygen for proper gas combustion; see Figure 17.

Minimum requirements for free air supply openings: one 12 inches from the ceiling for ventilation and one 12 inches from the floor for combustion air as outlined in the National Fuel Gas Code, ANSI Z223.1, or Local Building Codes.

The air supply openings should be sized according to table 5.

### CAUTION

Chemicals should not be stored near the heater installation. Combustion air can be contaminated by corrosive chemical fumes which can void the warranty.

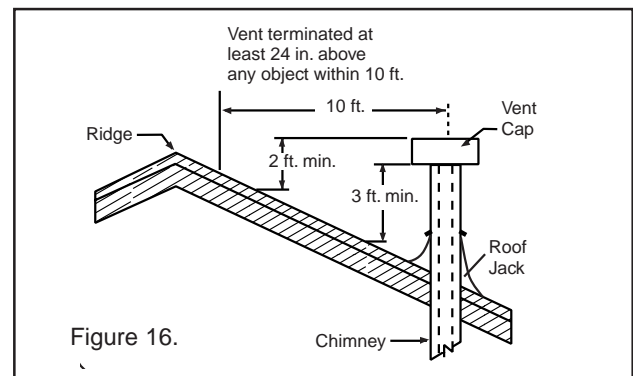

Figure 16.

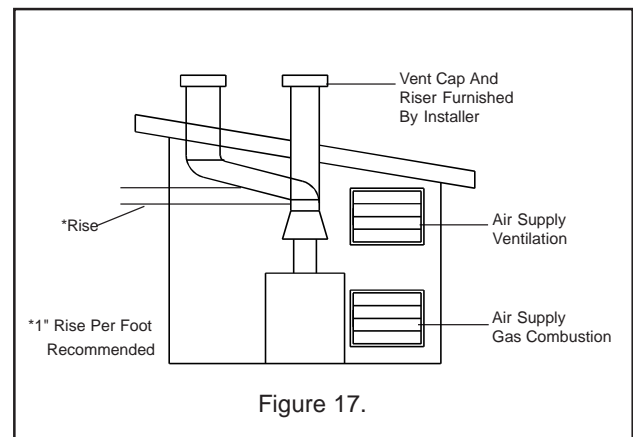

Figure 17.

### Air Opening Requirements

Model	Air For Combustion	Air Ventilation
100 DSI	100 sq. in.	100 sq. in.
100 MV	100 sq. in.	100 sq. in.

Table 5.

## VENT TEST

Use the following steps to perform a quick check of your venting installation. Allow the heater to operate for 15 minutes. Close the doors in the room, then strike a wooden match and blow out the flame. Hold the smoking match next to the draft hood; see Figure 18. If the smoke is pulled up into the vent and out of the room, the venting is correct. If it does not, you must make venting corrections.

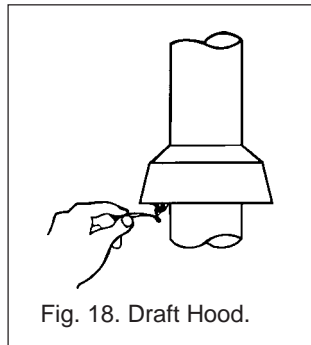

Fig. 18. Draft Hood.

## Stack Type Indoor Draft Hood Kit

Model	Draft Hood	Product No.	Vent Dia.
100 DSI	DH 10	471187	5 in.
100 MV	DH 10	471187	5 in.
100 SC	DH 10	471187	5 in.

## Indoor Draft Hood Installation

1. Take out slotted outer top piece after first removing sheet metal screws, attaching it to the cabinet.
2. Install adapter (vent kit).
3. Install top cover (vent kit).
4. Install draft hood (vent kit).

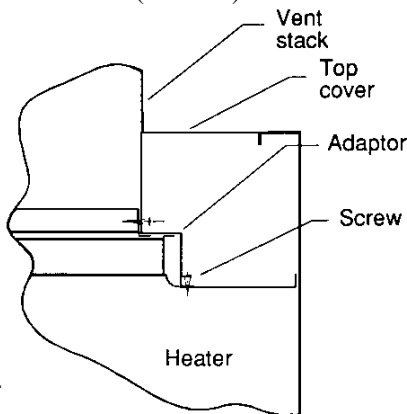

Figure 19.

Use provided screws to secure the vent assembly; see Figure 19.

## ELECTRICAL, DSI UNITS

Some versions of the MiniMax DSI Heater have a standard 120 VAC, grounded, 3-blade cordset factory installed for your convenience. The plug must be plugged into an outdoor rated watertight GFCI protected receptacle rated for 10 amps minimum - a constant power source is recommended. If the heater must be hard wired, you must remove the cord from

the terminal block located inside the junction box before removing the cord and strain relief from the cabinet. The heater may be hard wired with either 120 or 240 VAC - to convert to 240 VAC, change the transformer wiring connected to the output side of the terminal block first. The heater must be grounded and the heater electrically bonded.

All wiring must comply with all local codes, or in the absence of local codes with the NEC ANSI/NFPA 70.

### Electrical Rating

<b>60 Hz</b>	<b>115 V.A.C. or 230 V.A.C.</b>
<b>50/60 Hz</b>	<b>208 V.A.C. or 240 V.A.C.</b>

### NOTE

If any of the original wiring supplied with this heater must be replaced, installer must supply (No. 18 awg 105° C. U.L. approved AWM low energy stranded) copper wire or it's equivalent.

**In Canada:** wires must be CSA approved.

## CAUTION

The heater must be electrically grounded and bonded in accordance with local codes or, in the absence of local codes, with the latest national electrical codes ANSI/NFPA No. 70.

**In Canada:** CSA standard C22.1 Canada Electrical Code Part 1 and/or local codes.

## TRANSFORMER WIRING INSTRUCTION

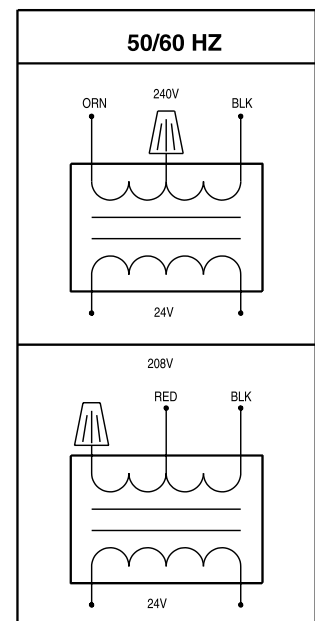
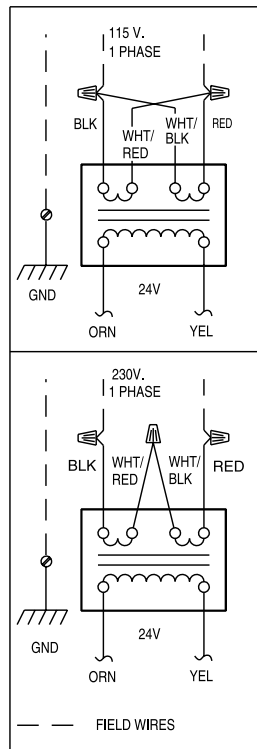

### MiniMax 100 Electronic Direct Spark Ignition Wiring Diagram

**MiniMax 100 ELECTRONIC WIRING DIAGRAM**

IF ORIGINAL FACTORY WIRING MUST BE REPLACED, INSTALLER MUST SUPPLY UL OR CSA (IF CANADA) APPROVED WIRE, 18 GAUGE, 600V, 150° C TEMPERATURE RATING. THERMAL FUSE WIRING MUST BE REPLACED WITH UL OR CSA (IF CANADA) APPROVED WIRE, 18 GAUGE, 600V, 150° C TEMPERATURE RATING.. INTERCONNECTING WIRING TO APPLIANCE MUST CONFORM TO THE NATIONAL ELECTRICAL CODE OR SUPERCEDING LOCAL (WIRING) CODES.

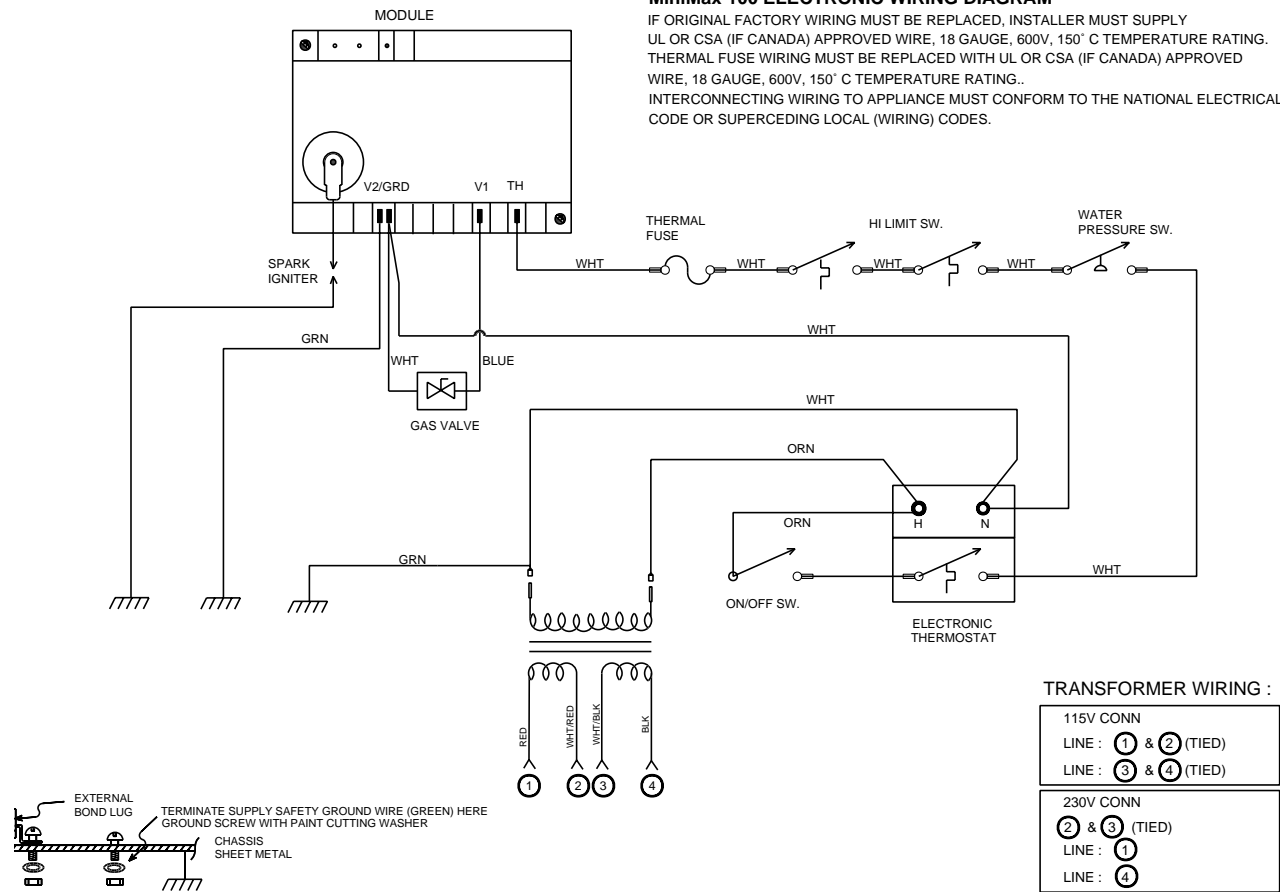

**TRANSFORMER WIRING :**

115V CONN
LINE : ① & ② (TIED)
LINE : ③ & ④ (TIED)
230V CONN
② & ③ (TIED)
LINE : ①
LINE : ④

### MiniMax 100 Millivolt Wiring Diagram

IF ANY OR THE ORIGINAL WIRE AS SUPPLIED WITH THE APPLIANCE MUST BE REPLACED, INSTALLER MUST SUPPLY (NO. 18 AWG 105°C U.L. & C.S.A. APPROVED FOR CANADA) COPPER WIRE.

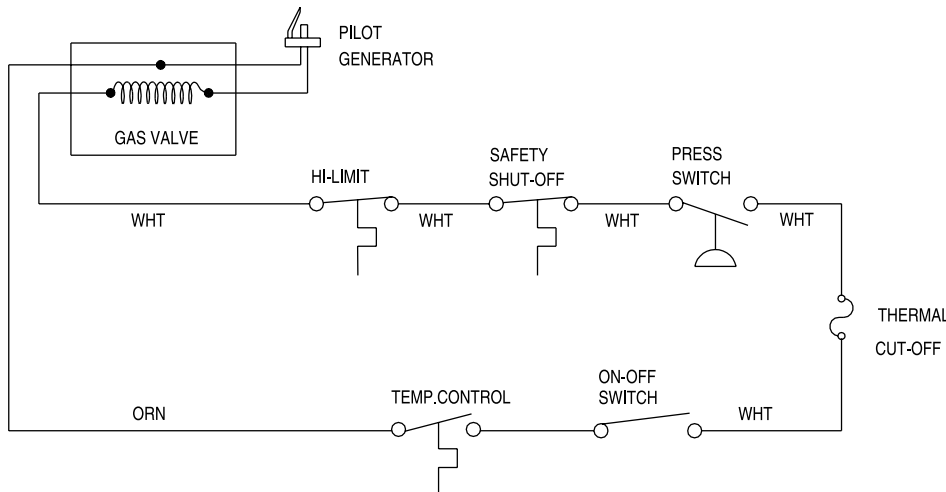

**Remote Wiring Hook-up**

The MiniMax 100 may be connected to a two wire remote control by disconnecting the wire connector from the hot (transformer) side terminal of the "ON/OFF" switch and connecting the two wire remote across the end of this wire and the aforementioned terminal.

**NOTE**

When connecting a remote control to the MiniMax 100 you must install the low voltage remote control wires in a separate conduit from ANY line voltage wires. Do not exceed 25 ft. wire run for remotes on millivolt models.

## TROUBLESHOOTING - GENERAL

Possible Cause	Remedy
Heater will not come on	
Automatic ignition system fails	Check if electrical connections are correct and securely fastened – If YES, call serviceman.
Pump not running	Place pump in operation
Pump air locked	Check for leaks
Filter dirty	Clean filter
Pump strainer clogged	Clean strainer
Defective wiring or connection	Repair or replace wires
Defective pressure switch	Replace Switch
Defective gas controls	Call serviceman
On-Off switch in "OFF" position	Turn switch to "ON"
Heater Short Cycling (Rapid On and Off Operation)	
Insufficient water flow	Clean filter and pump strainer
Defective wiring	Repair or replace wiring
Defective or stuck by-pass valve	Call serviceman
Defective hi-limit and/or thermostat	Call serviceman
Heater Makes Knocking Noises, Make sure all valves on systems are open	
Heater operating after pump has shut off	Shut off gas supply and call serviceman
Heater exchanger scaled	Shut off gas supply and call serviceman

# PARTS LIST

ITEM	DESCRIPTION	QTY.	P/N
1*	Indoor Draft Hood Kit consisting of: Indoor Draft Hood (471198) and items 2 & 3	1	471187
1A	Outdoor Top	1	471213
2*	Indoor Top (Cover)	1	471075
3*	Indoor Stack Adaptor	1	471214
4	Middle Top	1	471069
5	Flue Collector	1	471059
6	Return Header	1	471096
7	Bolt 3/8 x 16 UNC x 3/4	4	471200
8	Rubber Seal tube	10	470742
9	Heat Exchanger Less Heads	1	471093
10	Main Header (Inlet/Outlet)	1	471094
11	Combustion Chamber	1	N. A.
12	Ignitor Electrode Bracket	1	471058
13	Burner Natural Gas	1	471122
	Burner Propane	1	471136
	Burner (SC) Natural Gas	1	471851
13a	Burner Tray Assy. (complete) Natural Gas Millivolt	1	471219
	Burner Tray Assy. (complete) Propane Millivolt	1	471236
	Burner Tray Assy. (complete) Natural Gas DSI	1	471076
	Burner Tray Assy. (complete) Propane DSI	1	471077
	Burner Tray Assy. (SC) - (complete) Natural Gas	1	471850
14	Ignitor Electrode	1	471090
15	Gas Valve-Nat. Gas DSI-Robertshaw	1	471088
	Gas Valve-Propane DSI-Robertshaw	1	471089
	Gas Valve-Nat. Gas Millivolt-Robertshaw	1	471192
	Gas Valve-Propane Millivolt-Robertshaw	1	072125
	Gas Valve-Nat. Gas Millivolt-SIT	1	471436
	Gas Valve-Propane Millivolt-SIT	1	471435
16	Thermostat-Millivolt Models	1	072022
	Thermostat (Electronic)-Direct Spark Models	1	471431
17	On/Off Switch spst	1	471128
18	Heat Shield Burner Tray	1	471070
19	Control Panel Assy	1	471078
20	Door Assembly	1	471067
21	Control Bracket	1	471159
22	Ignition Control DSI	1	471091
23	Transformer	1	074033
24	Jacket Assembly	1	N. A.
25	Inspection Panel	1	471071
26	Burner Tray Back Support	1	471169
27	Burner Tray Side Support	2	471166
28	Heat Exchanger Support Brackets	2	471164
29	Hi-Limit Safety Switch	2	071017
30	Flow Valve, assy.	1	471095
31	Pressure Switch	1	471097
32	Baffle Hold Down Bracket	1	471064
33	Flue Baffle	4	471065
**	Items Below Not Shown		
**	Washer 3/8 I.D.	4	072169
**	Thermal Cutoff Switch	1	075173
**	Pilot Natural Gas Millivolt	1	471239
**	Pilot Propane Millivolt	1	471238
**	Thermopile Generator	1	071515
**	Quick-flange Kit for 2" slip connection	1	471215
**	Quick-flange II Kit for 1½" thd. connection	1	471083
**	Kit Wiring MMX 100 Millivolt	1	471201
**	Kit Wiring MMX 100 DSI	1	471202
**	Knob	1	470184
**	Knob Stopper	1	470414
**	Presslite Piezo Ignitor Assy-Millivolt	1	075459
**	Valve Drain 1/4 npt	1	072136
**	Hi-Tension Ignition Cable	1	471092
**	Rubber Bushing, 2" i.d.	2	070544
**	Pilot Bracket/Shield, Millivolt		471221
**	Manifold		471260
**	Cord-6' w/Plug		155138

# EXPLODED VIEW

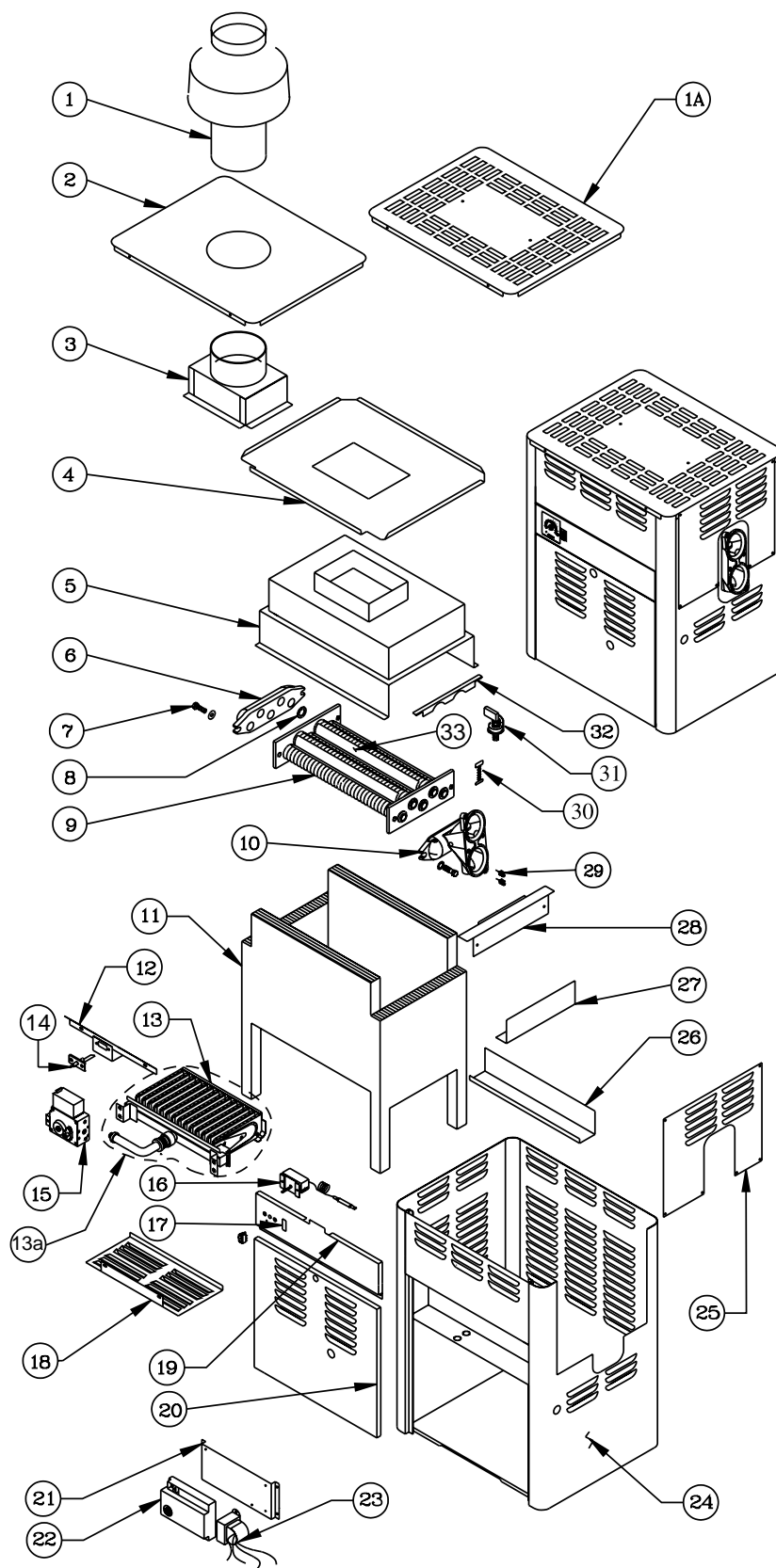



*Because reliability matters most*

## Pentair Pool Products Heater Limited Warranty

Your Pentair Pool Products pool heater is another quality product from Pentair Pool Products and is backed by the following warranty.

1. The following parts are warranted for one year from date of purchase:

The Pentair Pool Products cabinet and combustion chamber, the main burners and burner manifold, the inlet/outlet header and the return header. This warranty does not cover rusting or corrosion on cabinets or burners that does not affect the heater's operation.

2. The following parts are covered for one year from date of purchase:

The automatic flow control valve, all controls, heat exchanger, pilot generator and the pilot assembly.

3. This warranty only applies to the original purchaser.
4. This warranty shall not apply to any units or parts which have been subject to accident, negligence, alteration, abuse, misapplication or misuse.

The above warranty applies only if the heater is installed and operated in complete compliance with the installation and operation manual provided with each unit. Copies of this manual are available by writing to Pentair Pool Products at the address below.

Pentair Pool Products assumes no liability except for the repair or replacements of parts as specified above. Ship defective parts or equipment along with serial number and purchase date, transportation prepaid to the address below. Purchaser shall be responsible for freight charges for return of merchandise to purchaser. Some states do not allow exclusion or limitation of incidental or consequential damages so the above may not apply to you.

This warranty gives you specific legal rights, and you may also have other rights which vary from state to state.

### **SERIAL NUMBER**

(Please Fill In)

Pentair Pool Products  
 1620 Hawkins Ave., Sanford, NC 27330 • (919) 774-4151  
 10951 West Los Angeles Ave., Moorpark, CA 93021 • (805) 523-2400

Pentair Pool Products  
1620 Hawkins Ave., Sanford, NC 27330 • (919) 774-4151  
10951 West Los Angeles Ave., Moorpark, CA 93021 • (805) 523-2400

